

RTD series

THE NEW FAMILY OF TIPPING BUCKET RAIN GAUGES

INTRODUCTION

The **RTD series** includes the **new tipping bucket rain gauges** designed in **accordance with the recommendations of WMO-No. 8** ("Guide to Instruments and Methods of Observation").

Entirely made of **corrosion-resistant materials**, they ensure **accurate and reliable rainfall measurements** with minimal maintenance.

Rainwater collected by the aluminium funnel flows into a **calibrated tipping bucket**. Once the preset volume is reached, the bucket tips, empties the water, and returns to its initial position, generating an electrical pulse detected by a data logger or a pulse counter. The amount of rainfall is determined by the number of bucket tips.

A removable filter located in the funnel inlet prevents logging and simplifies cleaning operations.

Different models vary in **collector area, measurement resolution, output type, and heating system configuration**, to suit a wide range of application requirements.

FEATURES

Integrated diagnostic sensors

Built-in **temperature, humidity, pressure, and tilt** sensors continuously monitor both environmental and instrument conditions, ensuring optimal operation.

Robust construction

A metal base and a corrosion-resistant body ensure long-term reliability even in harsh environmental conditions.

Measurement accuracy

A **calibrated tipping bucket mechanism** provides consistent and precise pulse generation in full compliance with WMO standards.

Easy maintenance

The **removable inlet filter** and the **non-stick treated collector** cone simplify cleaning and ensure a smooth and regular water flow.

CONFIGURATION & MEASUREMENT

Detection mechanism

Tipping bucket system with electrical pulse generation via normally closed reed contact.

Output options

- Voltage-free NC contact output
- Digital outputs: RS485, SDI-12, MOSFET Open Drain
- Analog outputs: 4...20 mA or 0...10 V

Heated versions and heating control

Heated models with 12 or 24 V DC power supply and automatic activation threshold around +4 °C, featuring PID control (for digital/analog versions) or ON/OFF control (for contact output models).



www.senseca.com



WMO COMPLIANCE

Designed according to WMO-No.8 for standardized and reliable measurements.



DURABILITY

Built entirely from corrosion-resistant materials for long-term reliability.



ACCURACY

Calibrated tipping bucket ensures precise rainfall measurement.



ALL-WEATHER OPERATION

Heated versions automatically prevent ice and snow; PID control optimizes power use.



LOW MAINTENANCE

Removable filter and non-stick collector cone simplify cleaning.



FLEXIBLE INTEGRATION

Multiple output options for seamless data acquisition and system compatibility.

Technical Specifications

| | |
|-----------------------|---|
| Collecting area | 200 cm ² (RTD02...) or 400 cm ² (RTD04...) |
| Power supply | |
| Heating excluded | 7...30 Vdc (RTD...Fx, RTD...Dx e RTD...Vx) RTD...0x does not require power supply |
| Only heater | 24 Vdc ± 10% |
| Consumption | |
| Heating excluded | < 7 mA @ 24 Vdc (RTD...Fx and RTD...Vx) < 29 mA @ 24 Vdc (RTD...Dx) RTD...0x has no consumption |
| Only heater | 75 W (RTD02...) / 110 W (RTD04...) |
| Output | <ul style="list-style-type: none"> • Voltage-free NC contact (RTD...0x) • RS485 (RTD...Fx, RTD...Dx e RTD...Vx) • SDI-12 (RTD...Fx) • MOSFET Open Drain (RTD...Fx) • 4...20 mA (RTD...Dx) • 0...10 V (RTD...Vx) |
| Resolution | 0.1 – 0.2 or 0.5 mm/tip depending on model |
| Accuracy | <± 2 % (up to 200 mm/h using correction curves). With the analog and digital output options, the curves are stored in the rain gauge itself. |
| Maximum rainfall rate | 600 mm/h (versions with 0.1 and 0.2 mm nominal resolution) 1000 mm/h (version with 0.5 mm nominal resolution) |
| Operating temperature | |
| Without heating | 0...+70 °C |
| With heating | -25...+70 °C (heating intervention temperature +4 °C) |
| Connections | M12 connector for the output PG7 cable gland for the heater power supply |
| Protection degree | IP 65 |
| Weight | ~2.5 kg (RTD02...) / ~3 kg (RTD04...) |
| Material | Anodized and painted aluminum alloy |
| Installation | On Ø40...60 mm mast |

Dimensions

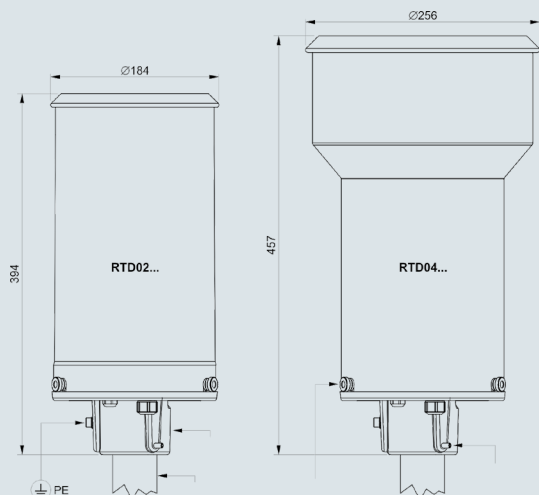

Installation

Installation is designed to be simple and versatile: just place the instrument on a Ø40–60 mm mast and secure it using the supplied Allen screws. Optional accessories are available for **easy mast mounting on both flat surfaces** (HD2003.78) and **directly into the ground** (HD2003.75).

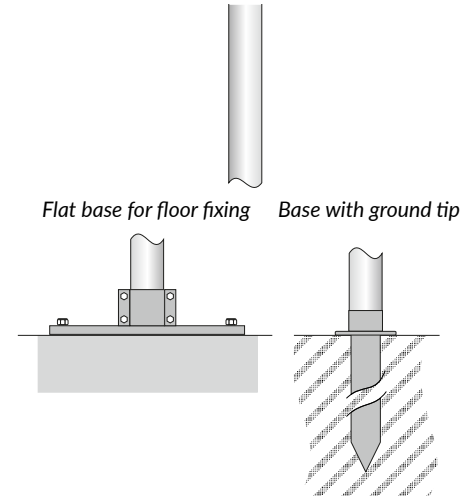

To guarantee the correct operation of the tipping mechanism, **each rain gauge features an integrated bubble level for quick and precise alignment.**

Ordering codes

RTD

| |
|--|
| Heating 0 = no R = yes |
| Output 0 = Potential-free NC contact F = RS485, SDI-12 and MOSFET Open Drain D = RS485 and 4...20 mA V = RS485 and 0...10 V |
| Resolution 1 = 0.1 mm 2 = 0.2 mm 5 = 0.5 mm |
| Collecting area 02 = 200 cm ² 04 = 400 cm ² |

The rain gauge is supplied with fixing screws, M12 female free connector (only if the optional cable is not ordered) and calibration report. Cables and fixing accessories must be ordered separately.

vs1.0