

Safety handles VF AP-S

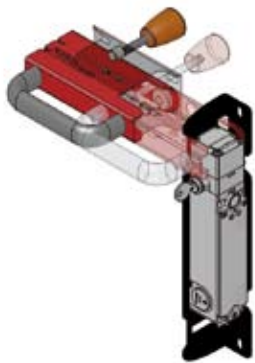

To apply safety switches on machinery guards we must confront with practical issues relating to ease of installation, precise mechanical movements of the guard, the occurrence of critical environmental conditions.

Moreover, frequently the guards are used by clumsy operators and in some cases even by persons not qualified or not familiar with the operative principles of machineries.

These problems become important when the guard is a door to a protected area. The physical dimensions of this type of repair and the related construction tolerances cause problems of alignment with the consequent risk of damage to the security devices.

The new safety handle VF AP-S arises from Pizzato Elettrica twenty-five-year experience in safety sector.

This integrated closing device can be applied on guards or protections of perimetric safety barriers, where it is required control on access to dangerous areas of a machinery or plant.

The new safety handle VF AP-S unlike other products on the market, combines its own characteristics of compactness and lightness deriving from its sliding movement, with its sturdiness, this last one being a characteristic present in superior models which, though, are heavier, bigger and structurally more complex.

Structure

The light and compact VF AP-S handle has a metallic structure, galvanized and painted, and a plastic or aluminium handle ergonomically studied to give a more comfortable hold and to ease the use of the handle itself.

The absence of screws and detachable components prevent any tempering.

Centering

The "C" shape of the handle final part allows the device centering in case of misalignment between guard and frame. This way there is the best alignment between switch and actuator preventing any damage due to possible collisions.

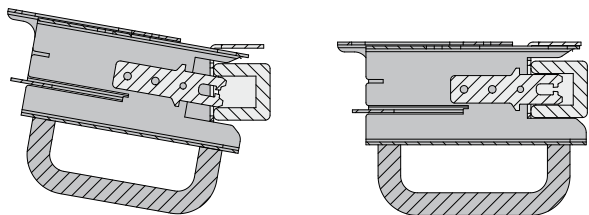

Actuator and switch protection

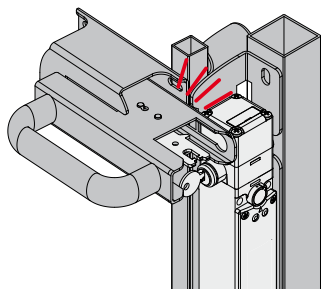

The structure of the handle and of the switch fixing bracket allows the positioning of both the switch and the actuator safe from dangerous collisions. Impacts due to wrong operation are completely discharged on the handle structure.

Handle lock positions

There is a snapping device which keeps the handle locked in two positions: when it is open, in order to increase the actuator holding force and when it's retracted to avoid unwanted opening due to machinery vibrations.

Emergency opening internal lever

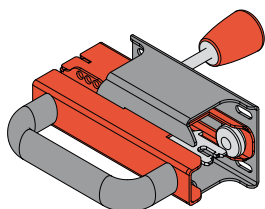

Optional lever for emergency opening from inside: it allows the exit of staff accidentally trapped inside the dangerous area. Only to be combined with switches without block (e.g. FD ●93) or with emergency release push button (e.g. FG ●●D6D●●).

Accessories See page 6/1

Assembling flexibility

The symmetrical design allows the application on swing and sliding doors with right or left closing, no adjustment needed.

The slotted brackets and the wide actuator extraction travel (60 mm) allow to assemble and adjust the device on different profiles.

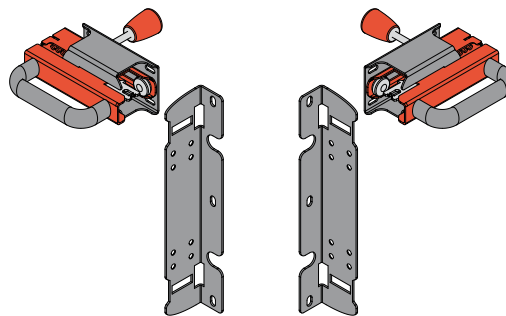

Mechanical stop

When closing the door there is a mechanical stop (A) whose function is to avoid possible impacts between actuator and switch leaving a safety distance (B) between these two elements and the switch housing.

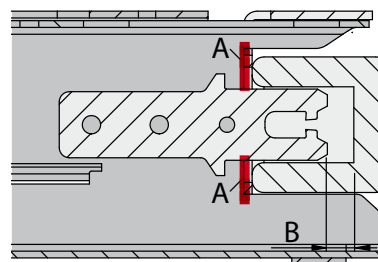

Locking option

It is possible to apply up to 6 padlocks whose function is to prevent the door mechanical closing and consequently the casual switching of the contacts. Padlocks diameter holes 7 mm

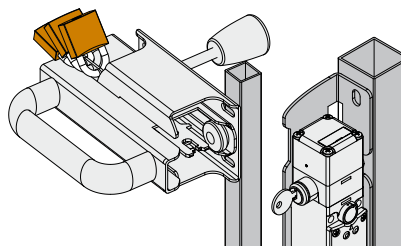



Code structure

VF AP-S13BP-200

Brackets preset for fixing	
A	FD ●●●●
B	FG ●●●●●●

Emergency opening internal lever	
P	with emergency opening internal lever
Z	without emergency opening internal lever

Plates configuration	
001	without plate with aluminium handle
002	without plate with plastic handle
200	with plate for FG: with screwed aluminium handle
201	with plate for FD: with screwed aluminium handle
300	with plate for FG: with screwed plastic handle
301	with plate for FD: with screwed plastic handle

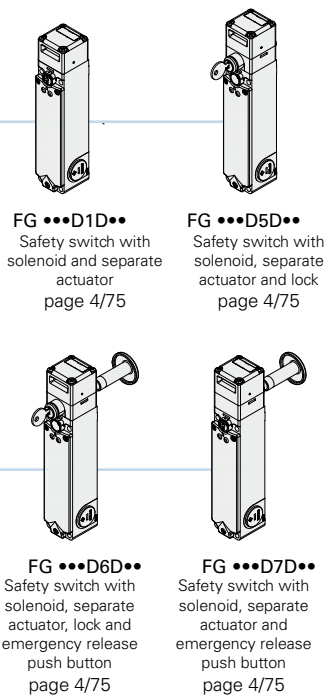
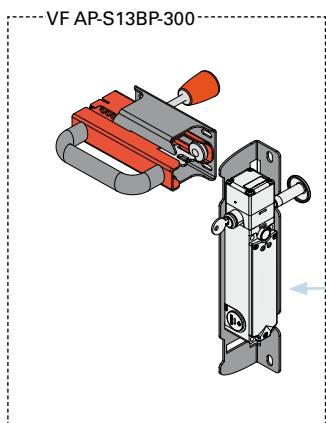

Safety handle VF AP-S13BP-300

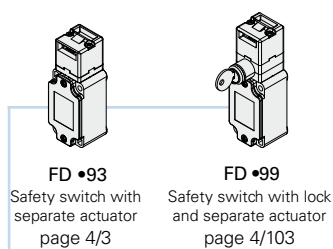
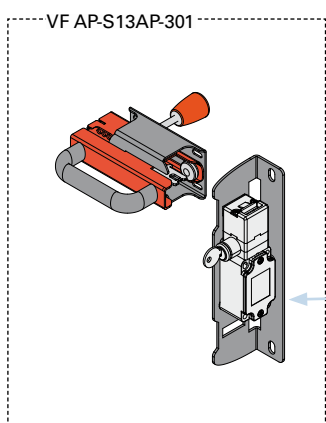
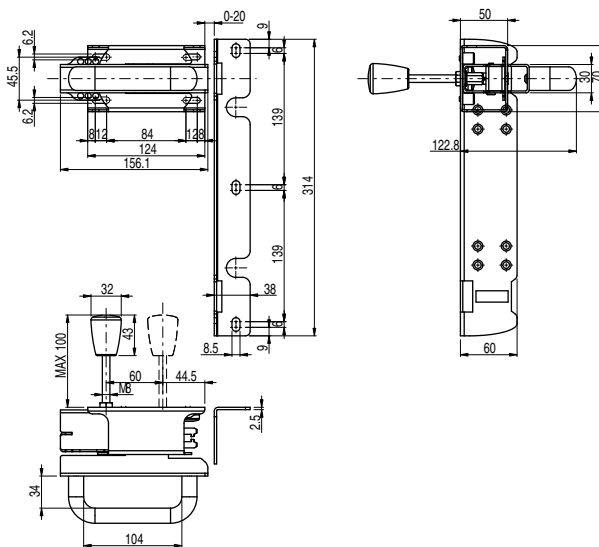

Safety handle VF AP-S13AP-101

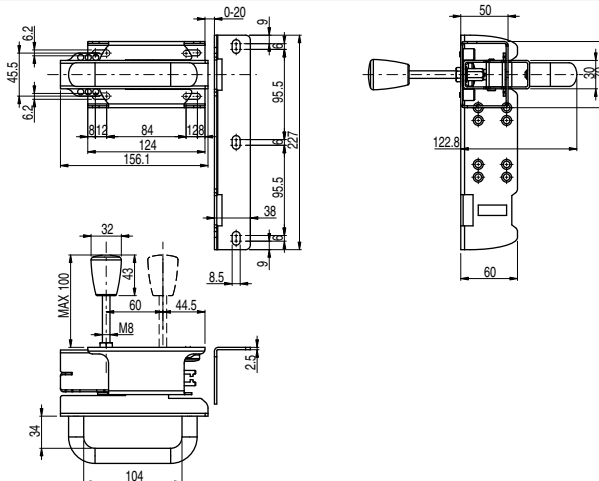

Safety switches FD and FG series

Safety switch with separate actuator
FD series

Main data

- Metal housing or polymer housing, from one to three conduit entries
- Protection degree IP67
- 9 contact blocks available
- M12 assembled connector versions
- Silver contacts gold plated versions



Safety switch with solenoid and separate actuator
FG series

Main features

- Actuator holding force 2500 N
- 20 contact blocks with 4 poles
- Metal housing, three conduit entries M20
- Protection degree IP67
- Version with lock release device and emergency release push button
- Signalling LED
- Working with energized or de-energized solenoid

